

Portable Clean Room & Hood

Preliminary Report

Katie Hoffman

Daniel Marquez

Hannah Reed

2018-2019



**Department of Mechanical Engineering
Northern Arizona University
Flagstaff, AZ 86011**

Project Sponsor: Anevas Technology, Inc.

Faculty Advisor: Dr. Timothy Becker

Instructor: Dr. David Trevas

DISCLAIMER

This report was prepared by students as part of a university course requirement. While considerable effort has been put into the project, it is not the work of licensed engineers and has not undergone the extensive verification that is common in the profession. The information, data, conclusions, and content of this report should not be relied on or utilized without thorough, independent testing and verification. University faculty members may have been associated with this project as advisors, sponsors, or course instructors, but as such they are not responsible for the accuracy of results or conclusions.

TABLE OF CONTENTS

Contents

DISCLAIMER	i
TABLE OF CONTENTS	ii
1 BACKGROUND	1
1.1 Introduction	1
1.2 Project Description	1
1.3 Original System	1
2 REQUIREMENTS	2
2.1 Customer Requirements (CRs)	2
2.2 Engineering Requirements (ERs)	2
2.3 House of Quality (HoQ)	3
3 EXISTING DESIGNS	4
3.1 Design Research	4
3.2 System Level	4
3.2.1 Existing Design #1: Vertical Laminar Flow Hood	4
3.2.2 Existing Design #2: Horizontal Laminar Flow Hood	5
3.2.3 Existing Design #3: NCI 8'x8'x8' Portable Clean Room	6
3.2.4 Existing Design #4: Clean Air Products 6'x8'x8' Portable Clean Room.....	6
3.3 Functional Decomposition.....	7
3.3.1 Black Box Model	7
3.3.2 Work Process Diagram.....	8
3.3.3 Functional Model	9
3.4 Subsystem Level.....	9
3.4.1 Subsystem #1: Portable Clean Hood.....	9
3.4.2 Subsystem #2: Portable Clean Room.....	10
3.4.3 Subsystem #3: Portable Clean room with clear walls	10
4 DESIGNS CONSIDERED	11
4.1 Portable Hood Designs	11
4.1.1 Design #1: Portable Hood with Exterior Frame.....	11
4.1.2 Design #2: Slide on External Frame Clean Hood	11
4.1.3 Design #3: Vertical Laminar Flow Hood with Solid Frame.....	12
4.1.4 Design #4: Horizontal Laminar Flow Hood with no Frame	13
4.2 Portable Clean Room Designs	14
4.2.1 Design #5: Clean Room with Detachable Frame	14
4.2.2 Design #6: Double Flap Clean room.....	15
4.2.3 Design #7: Portable Clean Room Single Flaps	16
5 DESIGN SELECTED.....	18
5.1 Rationale for Design Selection	18
6 CONCLUSION	19
7 REFERENCES	20
8 APPENDICES	21
8.1 Appendix A: Portable Hood with Adjustable Frame	21
8.2 Appendix B: Portable Hood with Tabbed Framing	21

1 BACKGROUND

1.1 Introduction

The clean room project was created by Anevas Technologies, Inc and is overseen by Dr. Timothy Becker. The project objective is to design and build a portable clean room and hood. The clean room and hood are to produce and maintain a positive pressure, which will reduce the number of foreign particles in the structures. This makes a clean environment for which the sponsor can conduct sterile experiments and test in. The company manufactures and analyzes minimal invasive microcatheter medical devices, used to treat aneurisms and other vascular defects in the brain. This project will benefit the client's research and development of their products by producing a clean low particle count environment.

1.2 Project Description

Following the original project description provided by Anevas Technologies, Inc.,

“The scope of this project is to design, build, and test a fan-filter unit (FFU), a curtain clean room area, and a laminar flow hood to help establish sterile manufacture capabilities. The flow hood (2' x 4') and clean room (4' x 6') must have the ability to be disassembled and reassembled, clean and sterilized, and portable.”

The flow hood is to be 2' x 3' x 3' so it can fit over small equipment within the client's lab, along with an FFU placed on top of the frame to induce a positive pressure of clean air. The clean room has been changed to be 5' x 7' x 7.5' per clients request. It must have the ability to be assembled, disassembled, and carried by 3-4 people; it will have two FFUs placed on top of the frame to cause the positive pressure of clean air within.

1.3 Original System

This project involved the design of a completely new portable clean room and clean hood. There was no original system when this project began.”

2 REQUIREMENTS

The requirements of this project include the customer requirements and the engineering requirements. The customer requirements were provided directly from the client/sponsor. The engineering requirements are derived from the customer requirements and are given a unit for measurement and/or a targeted value.

2.1 Customer Requirements (CRs)

The customer requirements were obtained during the first client meeting and from the project description they are listed below.

- Positive pressure – maintained a controlled clean environment
- Inexpensive – low cost and remain within budget
- Clean – meet FDA classification requirements of number of particles in the air per cubic meter
- Portable – ability to be assembled, disassembled, and be carried by 3-4 people
- Visibility – ability to see inside the structures
- Reliability – reassurance that the structure will not fail
- Durability – last for an extended amount of time
- Noise – low emission of noise from FFUs

From the quality function deployment (QFD) chart, as seen in Table 2, the positive pressure and inexpensiveness were weighted the heaviest because they were emphasized the most by the client. While visibility was weighted the lowest because the given material is already transparent. Each customer requirement was obtained by the project description as well as the client.

2.2 Engineering Requirements (ERs)

From the customer requirements, engineering requirements were compiled to meet the CRs and are listed below. The different parameters used for the technical terms are given by table 1. Measuring the area of both the hood and the room is in terms on m^2 . The second parameter would be the pressure for each room and is measured in pascals. Also identifying the total potential cost for the room and the hood which is denoted, this is in dollars. An important factor for the ability to transport both the hood and the room is the assembly time which is in minutes. The power generated for both systems is denoted by watts. The velocity for each fan unit will be measured in m/s which will be used to understand positive pressure through the system. The overall sounds coming from each system will also be taken into consideration, this will be measured in decibels and the stress factors within the frame while holding the fans will be measured in pascals.

Table 1. Customer Requirements

	Area (m^2)	Pressure (Pa)	Cost (\$)	Weight (kg)	Assembly Time (min)	Power FFU (W)	Particle count (per m^3)	Velocity FFU (m/s)	Material	Sound FFU (dBa)
Hood	0.557	> 5890	1000	45.36	5	520	102,000	0.58	N/A	54
Room	3.26	> 5890	1000	54.43	30	1040	102,000	0.58	N/A	54

From the quality function deployment (QFD) chart, as seen in Table 2, the pressure and number of

particles had the highest score of 13. While the lowest scored ER was sound with a score of 1.4.

2.3 House of Quality (HoQ)

The House of Quality relates and compares the customer requirements to engineering requirements, to meet the client's expectations and desires for the project. The HoQ gives a visual of ERs that have greater importance or higher scores in relation to the ranked CRs. Each ER is given a specific target value that will allow for the design to meet the client's needs.

Table 2. House of Quality

System QFD		Project:	Aneuvus Technologies Inc. Clean Room and Hood																					
		Date:	September 20, 2018																					
		Input areas are in tan																						
Dimensions -Area	m ²																							
Pressure	Pa																							
Weight	kg	(++)																						
Cost	\$\$	(++)		(++)																				
Assembly Time	min			(++)	(+)																			
Power	W		(+-)		(+/-)																			
Number of Particles	m ³		(++)		(+/-)		(++)																	
Velocity	m/s		(++)				(++)	(++)																
Hood Material	n/a	(++)		(++)	(++)	(++)	(++)		(+)															
Room Material	n/a	(++)		(++)	(++)	(++)	(++)		(+)															
Stress	Pa		(++)									(+)	(++)	(++)										
Frequency	dBa				(+)					(+/-)														
Technical Requirements																								
Customer Needs		Customer Weights	Dimensions -Area	Pressure	Weight	Cost	Assembly Time	Power	Number of Particles	Velocity	Hood Material	Room Material	Stress	Sound										
Inexpensive	5	3			3	9	3	1	1		9	9			1									
Portable	3	9	1	3	3	9	3				1	1												
Positive Pressure	5		9		1		3	9	9				1	3										
Visibility	2						3				9	9												
Clean	4	1	9		3		3	9	3		9	9												
Reliability	3	3		1		1							9											
Durability	3	3				1					3	3	9											
Classification	5		9		9		3	9	1															
Noise	4																							
Technical Requirement Units			m ²	Pa	kg	\$\$	min	W	m ³	m/s	n/a	n/a	Pa	dBa										
Technical Requirement Raw Score			64	129	27	116	54	56	131	62	111	111	59	12										
Relative Weight %			6.9565	14.02	2.935	12.61	5.87	6.087	14.23913	6.73913043	12.07	12.07	6.413043	1.382										
Target ER Values Hood			0.7432		45.36	1000	2	576	102,000	0.58	-	-		54										
Target ER Values Room			2.23		54.43	1000	15	576	102,000	0.58	-	-		54										
Rank Order			6	2	11	5	9	10	1	7	3	4	8	12										

3 EXISTING DESIGNS

This section covers the design research, system level, functional decomposition and the subsystem level. Research was conducted to obtain a better understanding of portable clean rooms, their classification, the FFUs, and the type of material used for them. There are a variety of different designs for clean rooms, most clean rooms have similar features but key differences in where they are being used. Most clean rooms have clear walls for manufacturing visibility purposes, as well as a fan that provides the positive pressure in the room. Another difference is in the functionality of the room, for a portable clean room the legs will have wheels, for large equipment use the room will have an accommodating entry.

3.1 Design Research

There are many designs and concepts of portable clean rooms and hoods. Various companies were found through detailed online research, these companies manufacture portable clean rooms and hoods. There are two types of clean hoods, vertical laminar flow and horizontal laminar flow. The vertical and horizontal hood designs were reviewed and analyzed to meet the CR criteria. For portable clean rooms there are also two types, a soft-walled and a hard-walled clean room. These designs were evaluated to justify which concept best suited the client's conception.

3.2 System Level

There are a few existing designs that are like the design needed for this project. The clean rooms available with similar design requirements pertaining to this project are sold by various companies around the US. The requirements for most clean rooms are similar, they involve creating a laminar air flow and producing positive pressure to prevent particles from accumulating. Clean rooms vary by how clean the room needs to be for customer needs. Each clean room has different standards given the fan utilized, and these standards vary from 10,000 particles per cubic area to 100,000 particles per cubic area. Existing designs like a vertical laminar flow would be useful to create a clean room over a work area. Where a horizontal laminar flow hood is practical for some applications, pushing the flow towards the user, but would not be for this project's client needs.

3.2.1 Existing Design #1: Vertical Laminar Flow Hood

This hood produces a vertical laminar flow of clean air over the work space. This design is an ideal concept to analyze because it meets most of the CRs needed to satisfy the customer. It produces positive pressure, clean air, durable, reliable, and portable. It does not meet the cost or visibility requirement as seen in Figure 1 below.



Figure 1. Vertical Laminar Flow Hood [4]

3.2.2 Existing Design #2: Horizontal Laminar Flow Hood

The horizontal laminar flow hood produces a horizontal laminar flow. This design meets some of the requirements but is not the best design to analyze because the FFU is located on the back side of the hood. This design does not follow the client's specifications, which was having the FFU on the top of the hood due to limited surrounding space. Overall, a great perspective but does not meet the CRs entirely.

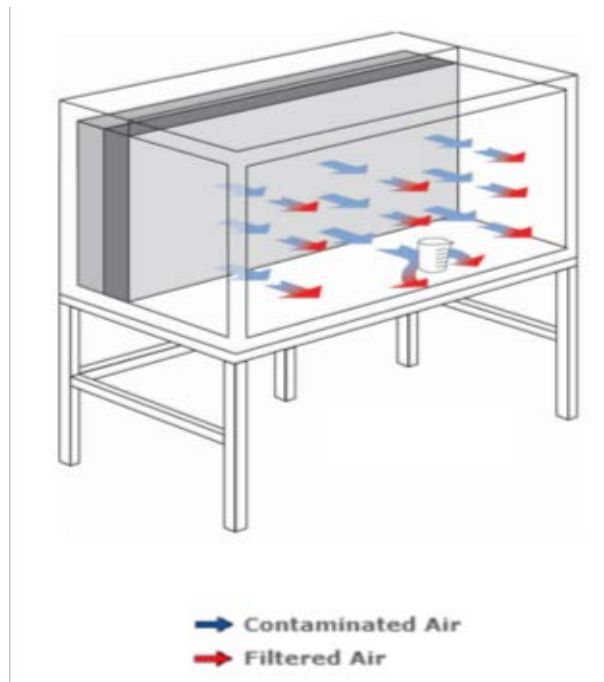

Figure 2. Horizontal Laminar Flow Hood [2]

3.2.3 Existing Design #3: NCI 8'x8'x8' Portable Clean Room

NCI created a clean room that very similar to the customer requirements needed for the clean room project. This portable clean room exceeds the size needed for the project but is portable. The main concern for this portable clean room would be if it could be carried out by three people or less, as specified in the CR's. Due to the size of this clean room created by NCI this may not meet the requirements of portability for the clean room project. Nevertheless, the design can be used for creative idea generation for the clean room project.

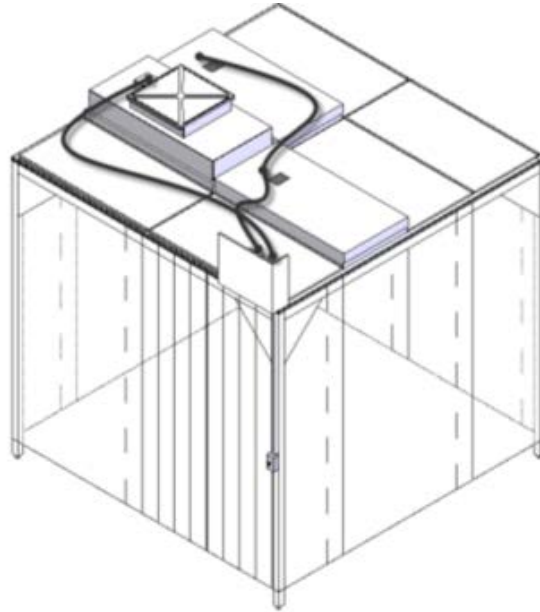

Figure 3. 8'x8'x8' Portable Clean Room [3]

3.2.4 Existing Design #4: Clean Air Products 6'x8'x8' Portable Clean Room

Clean Air Products created a portable clean room related to the requirements our client needs. The dimensions exceed the size needed for our customer needs, but it does meet the engineering requirement of being portable. This requirement is important since the room required by our client will be used in different areas. The concept of this clean room could be used as reference, since it meets some of the customer requirements needed for the clean room project.



Figure 4. 6'x8'x8' Portable clean room [1]

3.3 Functional Decomposition

The functional decomposition breaks down the entire system into smaller components. For this system a black box model and a functional model were created to obtain a better understanding and to simplify the project into smaller sections. These sections incorporate the basic principles of the black box and expand on it. Tracking the different flows like material, energy, and signal to create a logical flow rate of the processes going within the system. For material flow the operations of cleaning the room and utilization of using the hands are expanded upon and create a flow of what materials go in and out of the system. Energy flow is particularly a section of interest since this creates the main functionality of the clean room. The fans capture the kinetic energy coming from the clean room then releases it as laminar air flow which creates the positive air pressure. The electrical energy is used to power the fan which then engages the fans functionality. Human energy is introduced in the system when system under operation and humans are operating within the system. Signal flow is used to indicate whether the system is under operation and this allows the user to understand whether the clean room is on or off. The subsystems for this entire system depend on the requirements needed for this project. Subsystem one is the use of having a small clean room, this room needs to accommodate a certain dimension for it to meet the customer requirement. Subsystem two is about the portable clean room, using a soft wall to meet an engineering requirement of being light weight, for ease of transportation. Subsystem shows a portable clean room with clear walls, this meets a customer requirement of having visible walls.

3.3.1 Black Box Model

The black box model Figure 5 portrays a simple overview of the inputs and output of out of positive pressure structures. The three flows through the hood and the room are a material flow, energy flow, and signal flow.

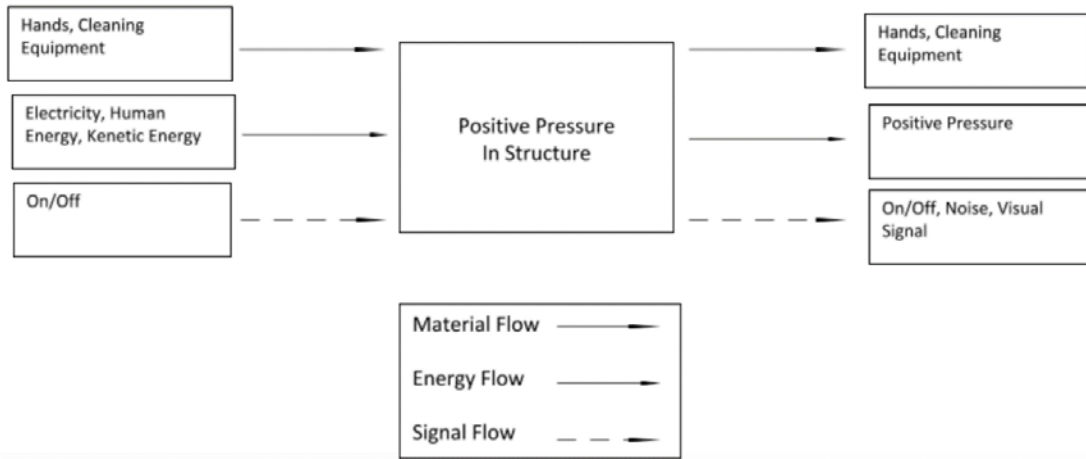

Figure 5. Black Box Model

3.3.2 Work Process Diagram

The work process diagram shows the hierarchal type work needed to create the clean room project. This figure illustrates the work needed to create the clean room proposed by the customer. It starts with the project description and then created ideas for the described project. Research is conducted using journals, the internet, and companies also implementing similar task. Proposed designs are compared and created by the team and resented to the client and iterated until the design takes shape. Once approved, possible prototypes of the design can be created. A final cost analysis with a list of different designs is created and presented to the client for final decision making. This creates the clean room that has been outlined by the work process diagram.

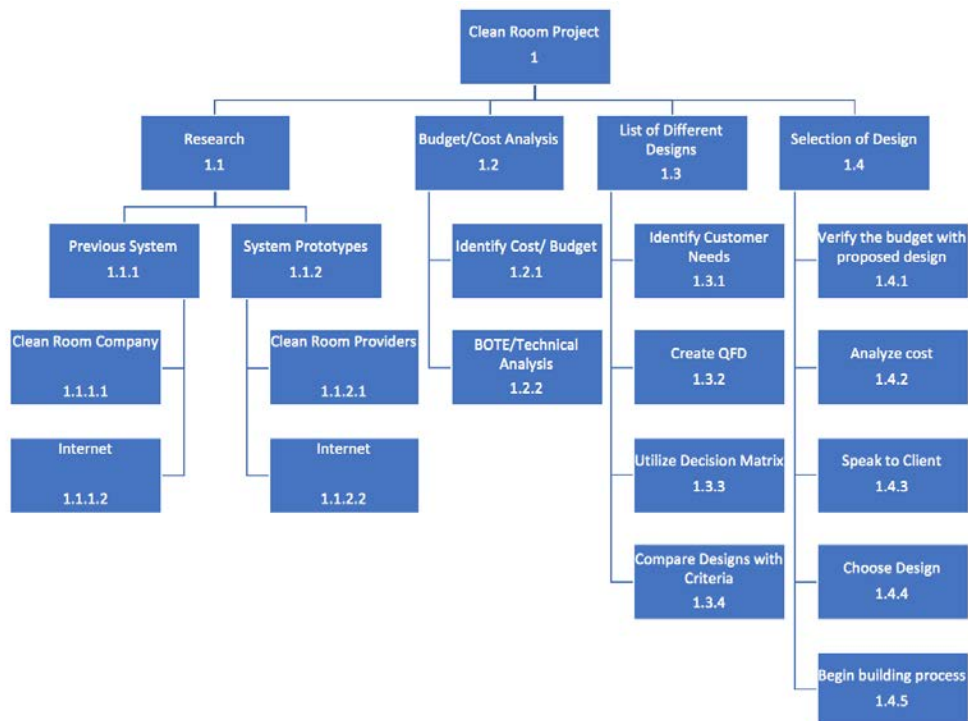

Figure 6. Work Process Diagram

3.3.3 Functional Model

The functional model is a breakdown of the process taken to achieve a successful clean room and hood. As seen in Figure 7 there are various broken-down steps that give a layout of what needs to be completed to obtain a successful finished project.

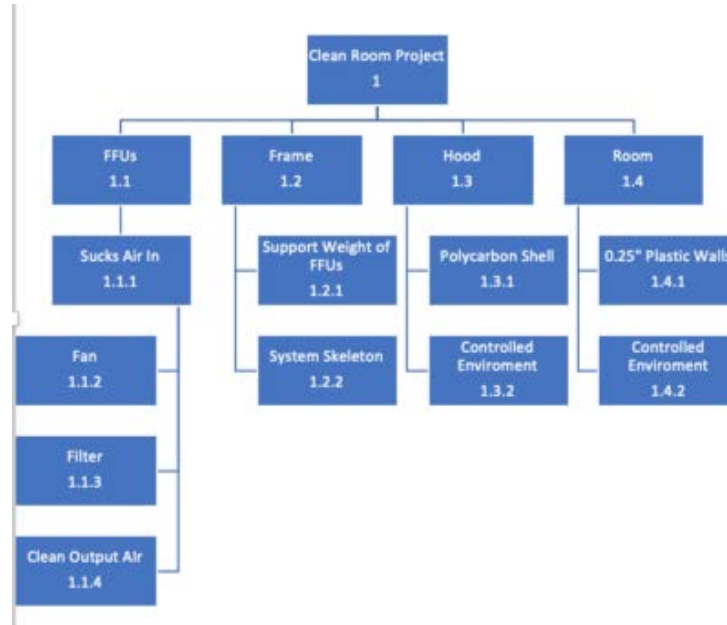

Figure 7. Functional Model

3.4 Subsystem Level

The subsystem shows the pre-existing designs that are currently being used by different clean room providers. The clean rooms that are relevant to this project will follow a set of customer requirements. The first requirement is portability. For the portable hood, it must be carried by a maximum of 2 people and for the portable clean room it must be carried for a maximum of three people. The other requirement is that each room must create positive air pressure within the system. For the clean hood one of the requirements is a specific plastic that is to be incorporated within, which is polycarbonate.

3.4.1 Subsystem #1: Portable Clean Hood

The portable clean hood is the main component for the first part of the project. This subsystem must be designed with very specific measurements for the client to use the system for a specific tool in the lab.

3.4.1.1 Existing Design #1: FFU

The Fan Filter Unit (FFU) is a pre-existing design that is being used through industry for all clean rooms. The FFU unit is important since it is the device that creates the positive air pressure for clean rooms. The level of cleanliness is also based on what type of FFU is being used, so the better the fan the higher level of cleanliness that can be acquired.

3.4.1.2 Existing Design #2: Frame

The frame is also a pre-existing model which consist of the outer skeleton of the portable hood. This frame is used to support the weight of the fan. This relieves pressure from the walls of the portable hood and adds durability of the overall portable hood.

3.4.1.3 Existing Design #3: Hood

The hood is roofing of the portable clean hood, this is where the fan is attached and connected to the frame. This hood is relevant since it creates the seal from the front to the walls of the portable hood.

3.4.2 Subsystem #2: Portable Clean Room

There are many portable clean rooms, client requirements specific and narrow the teams choices. For this clean room it required for the room to be lightweight and the ability to be transported with a max of 3 people. The clean room must meet a specific dimension based on the size of room described by the client, and the ability for 3 people to work within the clean room.

3.4.2.1 Existing Design #1: FFU

The FFU within this system will have to be powerful and have two fan units. The fans are a pre-existing design based on the cleanliness level needed for the customer. For this project the only objective needed for this room is to create a positive air pressure within.

3.4.2.2 Existing Design #2: Frame

Different frames have been used for the portable clean room, the frame that relates to this project is a frame that can be taken apart easily for three people. This will be the engineering requirement needed for the portable clean room.

3.4.2.3 Existing Design #3: Soft-wall

A soft wall design has also been used by different clean room providers. A soft wall implemented within the project would help meet the requirement of being lightweight.

3.4.3 Subsystem #3: Portable Clean room with clear walls

This subsystem shows a room that can be easily transported within rooms. Clean room providers have created a clean room that is both portable, but also having walls that are see through. This room is important since this subsystem could be implemented for the clean room project.

3.4.3.1 Existing Design #1: FFU

The FFU is a subsystem that has been pre-existing throughout the industry. Utilizing these fans can stray from the requirements needed by the client. For this project the fans engineering requirement is to create a positive air pressure.

3.4.3.2 Existing Design #2: Frame

The frame for this subsystem is a pre-existing system given the different types of clean rooms available. For this project the frame is attached to the room, the frame is supported by wheels at base making it portable. This meets the requirement needed for the clean room project.

3.4.3.3 Existing Design #3: Clear Walls

The subsystem of clear walls is an existing design that has been used throughout industry. The clear walls are an important feature to the clean room since visible walls are used to for transparency when manufacturing is a factor. Having these walls that are clear will comply with one of the requirements needed from the client.

4 DESIGNS CONSIDERED

This section describes the designs the team considered for selection of the final design. The section is broken up in to designs for the portable hood and designs for the portable clean room. Overall, it was difficult in considering designs because of the many restrictions through the client, FDA, and HEPA which limited our designs.

4.1 Portable Hood Designs

Below are concept designs for portable clean hoods.

4.1.1 Design #1: Portable Hood with Exterior Frame

Using an outer skeleton as a frame which reduces the strain on the polycarbonate walls of the room. The frame is used to hold the FFU and is sealed with the help of an adhesive which can be removed easily. The frame is made from aluminum which reduces the weight of the overall clean room. This helps with the ease of transportation which is a requirement by the customer. The polycarbonate walls have an entrance point that is 6inx12in which is required for working within the station. The bad thing about this device is the opening which is a hinge style opening which may reduce the visibility of the user when working. Another con may be the outer frame can also decrease the visibility when looking through the sides of portable hood.

Table 3. Pros and Cons of Portable Hood with Exterior Frame

Cons	Pros
Bad visibility due to frame	Lightweight
Bad visibility due to hinge opening	Clear Panels
Expensive material	Ease of work within clean room

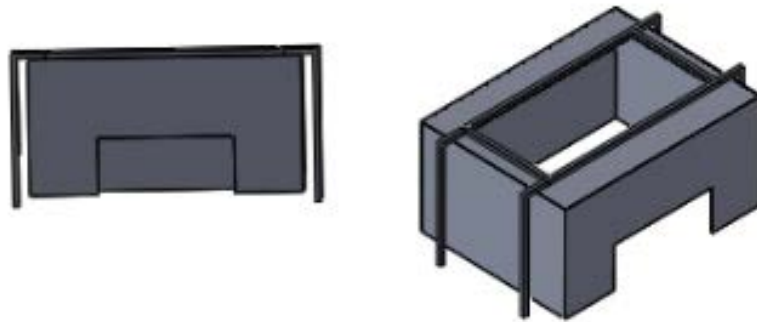

Figure 8. Design for Portable Hood with Exterior Frame

4.1.2 Design #2: Slide on External Frame Clean Hood

The design shown in figure 9 contains two parts, plus the FFU. The design is made so that the rubber feet on the bottom of the polycarbonate hood, can sit on the feet of the metal structure, this creates less movement of parts. The doors hinged on the polycarbonate structure open to the sides, rather than above, this removes the need for magnets or a latch to keep the door open while working. The metal frame has tabs that help to hold the FFU in place, rather than having the weight of the FFU sitting on the polycarbonate directly, this reduces the thickness of the polycarbonate and therefore reduces the price of

the polycarbonate.

Table 4. Pros and Cons of Slide on External Frame Clean Hood

Cons	Pros
Expensive materials	Lightweight
Thin polycarbonate	Low number of parts
Large components	Durable design
Hard to move	Simple construction

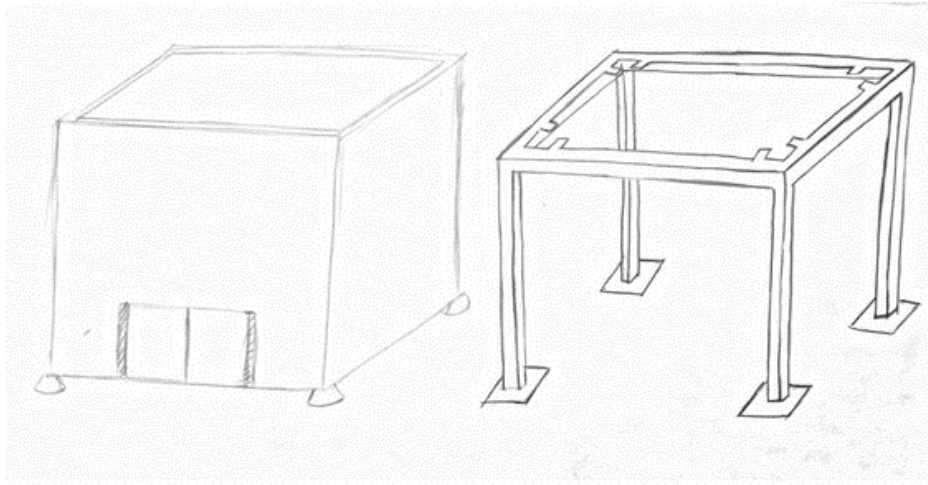

Figure 9. Design for Slide on External Frame Clean Hood

4.1.3 Design #3: Vertical Laminar Flow Hood with Solid Frame

The vertical laminar flow hood design in figure 10 has a separate aluminum frame with an inner polycarbonate shell and the FFU on top. The small door on the front has hinges on the top that attach to magnets to hold in place. This hood is designed as a solid combined piece which increases the weight but is a single system.

Table 5. Pros and Cons of Vertical Laminar Flow Hood

Cons	Pros
Expensive materials	Single system
Thick polycarbonate	Low number of parts
Large component	Durable design
Heavy	Simple construction

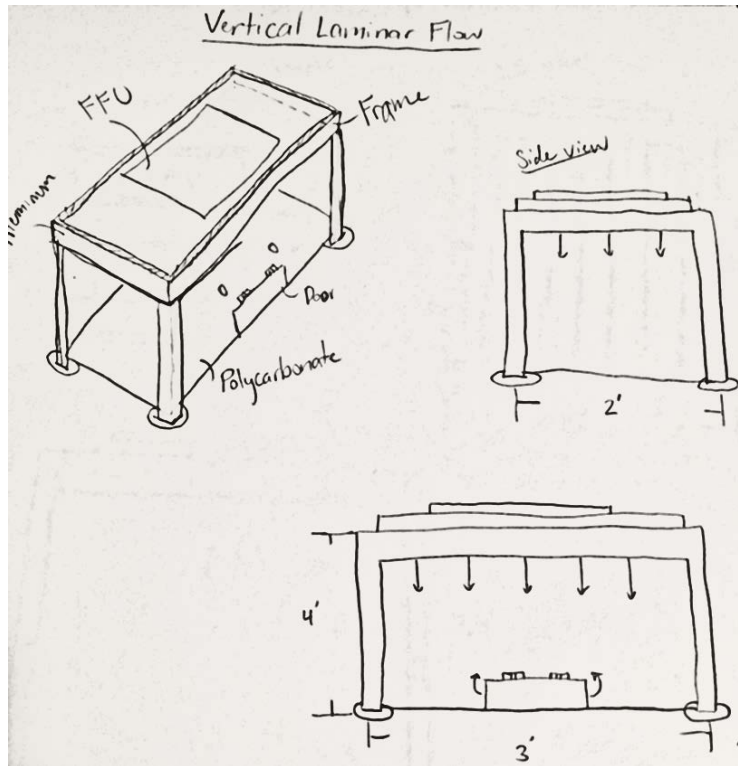

Figure 10: Vertical Laminar Flow Hood

4.1.4 Design #4: Horizontal Laminar Flow Hood with no Frame

The horizontal laminar flow hood design has the FFU unit on the back half of the system as seen in Figure 11. The front of the hood is open which will affect the positive pressure and with the FFU on the back will interfere with the equipment inside. With the FFU in the equipment will not be properly in the path of the clean filtered air. The polycarbonate walls may not have the ability to withstand the weight of the FFU.

Table 6. Design of Horizontal Laminar Flow Hood

Cons	Pros
Expensive material	Single system
Thick polycarbonate	Low number of parts
Large component	Durable design
Heavy	Simple construction

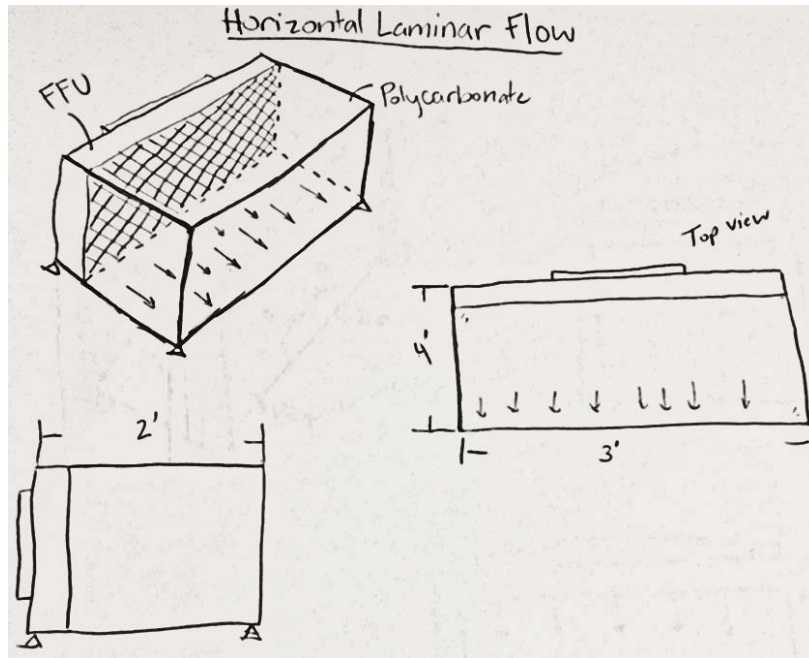

Figure 11. Design of Horizontal Laminar Flow Hood

4.2 Portable Clean Room Designs

Below are various concept designs for portable clean rooms.

4.2.1 Design #5: Clean Room with Detachable Frame

This design shows a clean room that has a frame which is adjustable based on the framing type being utilized. This concept tries to solve the issue of transportation through various locations. Using this type of framing will make it assembly and disassembly easier for the customer. The drawback is the use of the pricing on this type of material will raise the cost of the overall clean room.

Table 7. Pros and cons of Clean Room with detachable Frame

Cons	Pros
Cost of Frame	Lightweight
No wheels on room	Clear Panels
Assembly time	Durable Frame

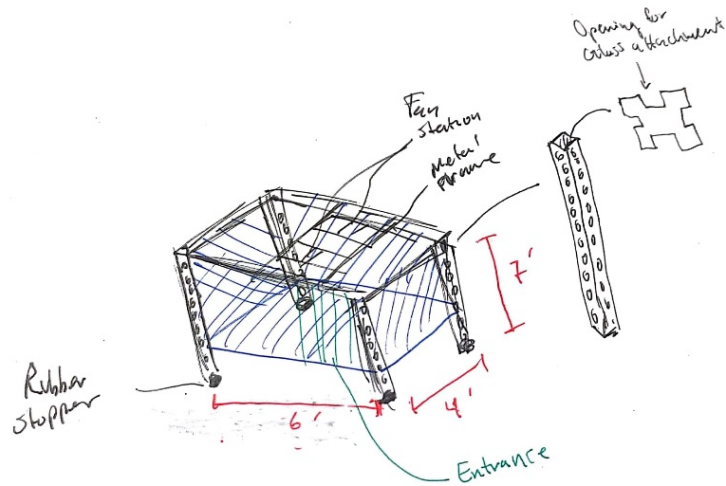

Figure 12. Design for Clean Room with detachable Frame

4.2.2 Design #6: Double Flap Clean room

The portable clean room in figure 11 shows the top view and front view. In the top view it can be seen there are two fans and the fans are spaced on the top for better air distribution. The fans are mounted in place and are supposed to be in the optimal position. In the front view the flaps on the entrance side are to have a double layer of plastic slats that are off set from each other to reduce the amount of air escaping, while the other three sides are solid vinyl sheeting, ensuring there is positive pressure in the structure. The bottom of the frame is to have castor wheels, so it can be easily moved, but also be locked in place.

Table 8. Pros and cons of Double Flap Clean room

Cons	Pros
Cost of Frame	Small pieces to carry
Fans don't slide/adjust	Clear panels
Assembly time	Durable structure
Fixed floor plan	Double layer of plastic sheeting at door
More material	Roll able/ moveable

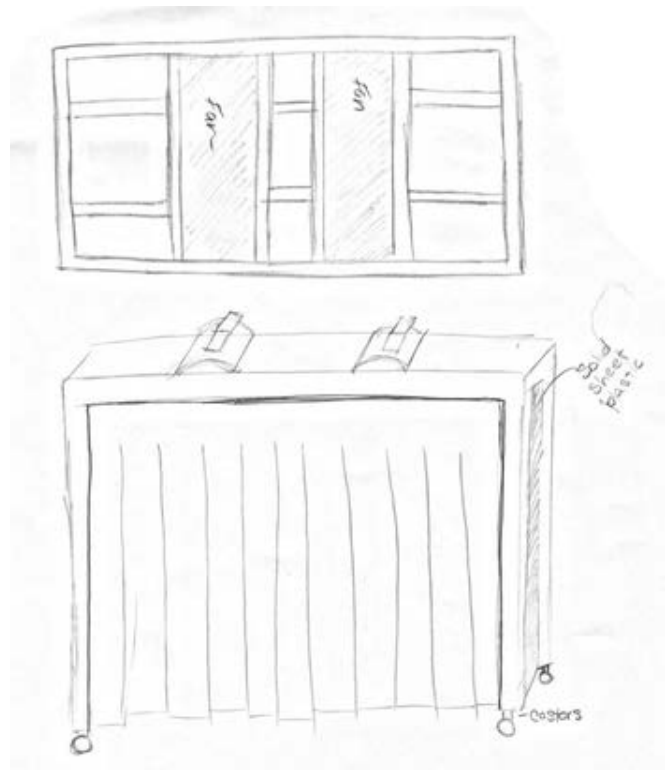

Figure 13. Design for Double Flap Clean room

4.2.3 Design #7: Portable Clean Room Single Flaps

The portable clean room as seen in Figure 14 below has two FFU units at the top, steel framing, clear plastic walls, with wheels as the feet, and single flap entrance unit. This system has steel framing with multiple pinned units this may create potential leaks of air but will be very heavy.

Cons	Pros
Heavy	Moveable
Fans don't slide/adjust	Clear panels
Multiple part	Durable structure
Potential small leaks	Easy to assemble

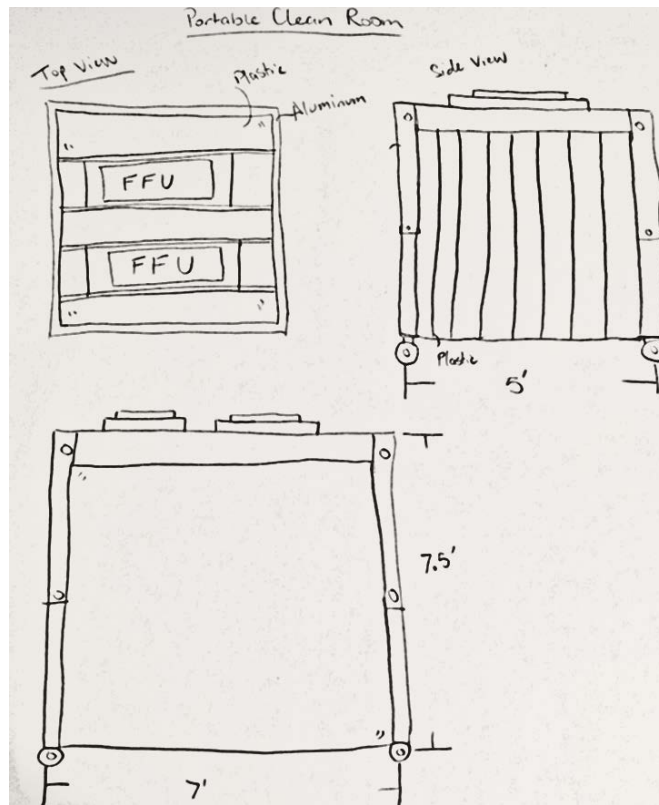

Figure 14. Design for Portable Clean Room Single Flaps

5 DESIGN SELECTED

Various design concepts were considered but due to the constraints of the CRs and needing to meet FDA criteria, the overall design selected was an aluminum framed polycarbonate clean hood and an aluminum frame clear walled plastic clean room. The selection of two possible design were made by comparing all the designs that we created with customer requirements. Using a Pugh chart, which used all of customer requirements and compared them to nine different designs. Each design was given a ranking according to the relevance to the CR's.

5.1 Rationale for Design Selection

The hood design and room design chosen met the all of the customer requirements while remaining under budget. The aluminum framing was decided because of how extremely lighter and durable the material is compared to steel, even though the cost is greater. The polycarbonate hood was specifically chosen by the client. The clear walled plastic was chosen for the visibility aspect, cost, and light weight. Rubber lining was chosen because of its elasticity and relative cost. The Pugh chart in table 9 is designed to show how each concept correlates with each CR. As seen in the Pugh chart, the hood design 2 and 4 ranked the highest because steel is cheaper than aluminum but is also heavy but are equivalent in all other aspects. The room designs all had a relative equal ranking but number 6 was the better option. The chosen designs for the hood and room can be seen in Figure 9 and Figure 13, respectively.

Table 9. Pugh Chart

Customer Requirements	1	2	3	4	5	6	7	8	9
Inexpensive	(-)	(+)	(-)	(+)	(-)	(-)	(+)	(-)	(+)
Portable	(+)	(+)(-)	(+)	(+)(-)	(+)	(+)	(+)(-)	(+)	(+)(-)
Positive Pressure	(+)	(+)	(+)	(+)	(+)	(+)	(+)	(+)	(+)
Visibility	(+)	(+)	(+)	(+)	(+)	(+)	(+)	(+)	(-)
Clean	(+)	(+)	(+)	(+)	(+)	(+)	(-)	(+)	(+)
Reliability	(+)	(+)	(+)	(+)	(+)	(+)	(+)	(+)	(+)
Durability	(+)	(+)	(+)	(+)	(+)(-)	(+)	(+)(-)	(+)(-)	(+)
Classification	(0)	(0)	(0)	(0)	(0)	(0)	(0)	(0)	(0)
Noise	(0)	(0)	(0)	(0)	(0)	(0)	(-)	(-)	(-)
Safety	(+)	(+)	(-)	(+)	(+)	(+)	(+)	(+)	(+)
Total (+)	7	8	6	8	7	7	7	6	7
Total (0)	2	2	2	2	2	2	1	1	1
Total (-)	1	1	2	1	2	1	4	3	3

1. Design 1 hood - Aluminum frame, polycarbonate hood, foam top lining

2. Design 2 hood - Steel frame, polycarbonate hood, rubber top lining

3. Design 3 hood - Aluminum frame, polycarbonate hood, rubber top lining

4. Design 4 hood - Steel frame, polycarbonate hood, foam top lining

5. Design 5 hood - Aluminum frame, acrylic hood, foam top lining

6. Design 1 room - Aluminum frame, 0.25" plastic wrap, duralock, lock pins

7. Design 2 room - Steel frame, 0.25" plastic wrap, velcro, latch locks

8. Design 3 room - Aluminum frame, 0.25" plastic wrap, velcro, latch locks

9. Design 4 room - Steel frame, 0.25" plastic wrap, duralock, lock pins

(+) - Positive Correlation

(0) - Neutral Correlation

(-) - Negative Correlation

6 CONCLUSION

This report contained background, customer and engineering requirements, existing designs, designs created, and the design selected for the portable clean room and clean hood. The main design parameter is for the flow hood and clean room to have the ability to be disassembled and reassembled, clean and sterilized, maintain a positive pressure, and portable. The team will be working to further improve the design selected to the client's specifications and request.

7 REFERENCES

- [1] “Clean Air Products,” *Modular Softwall Clean Rooms*. [Online]. Available: <https://www.cleanairproducts.com/softwall-cleanrooms>. [Accessed: 27-Oct-2018].
- [2] “Horizontal vs Vertical Laminar Flow Hoods,” *Terra Universal Blog*, 20-Feb-2018. [Online]. Available: <https://www.terrauniversal.com/blog/all-terra-blogs/horizontal-vs-vertical-laminar-flow-hoods/>. [Accessed: 27-Oct-2018].
- [3] “Softwall Cleanrooms[SWCR],” *Modular Softwall Cleanrooms | Vertical Flow | NCI*. [Online]. Available: <https://www.innotechprod.com/softwall-cleanrooms.html>. [Accessed: 27-Oct-2018].
- [4] “Vertical Laminar Flow Wash Out Base Clean Benches WO CAP412,” *Vertical Laminar Clean Benches | Flow Wash Out Base Clean Benches | WO CAP412 Cl*. [Online]. Available: <https://www.cleanairproducts.com/verticallaminarflowwashoutbasecleanbencheswocap412>. [Accessed: 27-Oct-2018].

8 APPENDICES

8.1 Appendix A: Portable Hood with Adjustable Frame

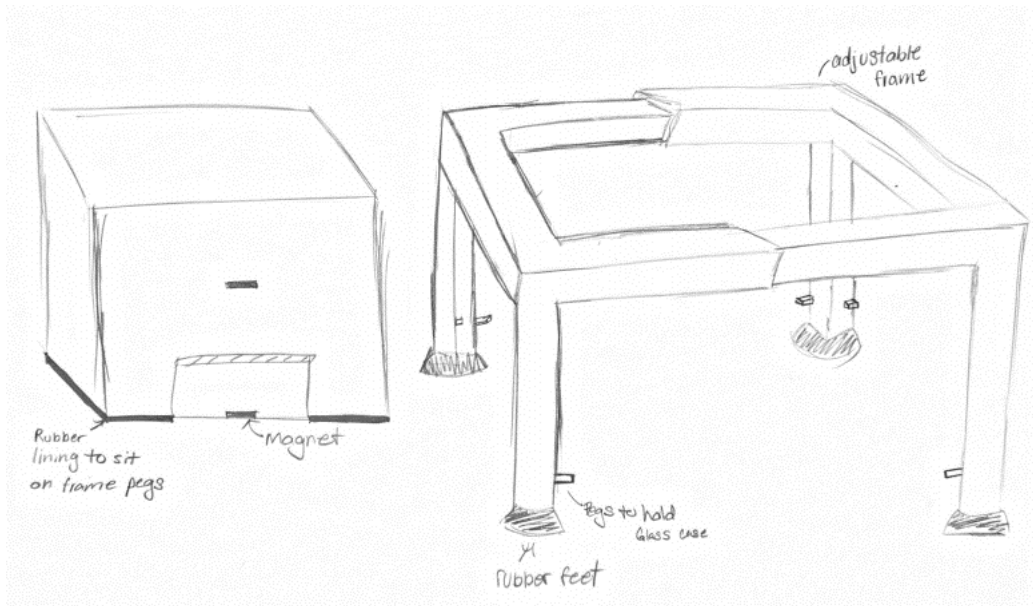

Figure 15. Portable Hood with Adjustable Frame

8.2 Appendix B: Portable Hood with Tabbed Framing

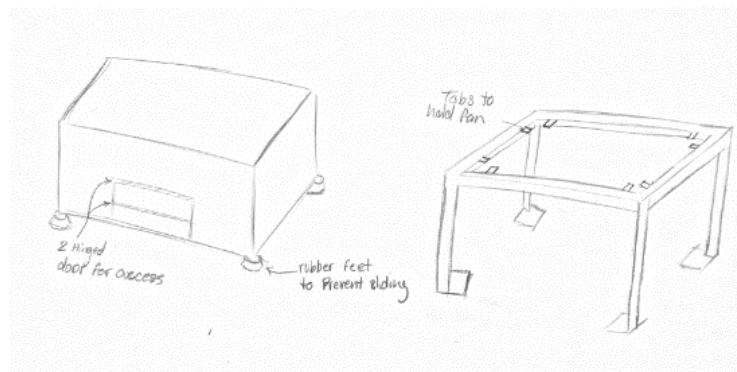

Figure 16. Portable Hood with Tabbed Framing